

Temperature Compensated Crystal Oscillators [TCXO " M " and VCTCXO " VM "]

CMOS Output

TCXO	VCTCXO	MHz range	CMOS	SMD	15pF	1.8 V	2.5 V	Min. 6.4 MHz	Max. 60.0 MHz
M _ T	VM _ T					3.0 V	3.3 V		

Features

- Wide frequency range : [6.4 MHz ~ 60.0 MHz]
- Frequency stability as tight as ± 0.5 ppm over 0°C to 50°C
- Frequency stability as tight as ± 1.0 ppm over -40°C to 85°C



General specifications of all available packages , at Ta=+25°C , CL=15pF

Output Waveform		Square wave [CMOS] . Waveform code is " T "							
Type	M32T , VM32T		M53T , VM53T		M572T , VM572T				
Package (Size)	(3.2 x 2.5 x 1.0 mm)		(5.0 x 3.2 x 1.3 mm)		(7.0 x 5.0 x 2.3 mm)				
Frequency Range	8.192 ~ 60.0 MHz		6.4 ~ 52.0 MHz		6.4 ~ 52.0 MHz				
Type	M43T , VM43T		M63T , VM63T		M47T , VM47T				
Package (Size)	(11.4 x 9.6 x 3.0 mm)		(11.4 x 9.6 x 3.0 mm)		(22.4 x 11.7 x 4.7 mm)				
Frequency Range	9.5 ~ 60.0 MHz		8.192 ~ 60.0 MHz		6.4 ~ 52.0 MHz				
Supply Voltage V _{DD} (code)			+1.8 V \pm 5% (code is " 18 ")	+2.5 V \pm 10% (code is " 25 ")	+3.0 V \pm 10% (code is " 3 ")	+3.3 V \pm 10% (code is " 33 ")			
Current Consumption. (max.) (Over operating temperature range .)	Package	M32T	6 mA	6 mA	6 mA	6 mA			
		M53T	6 mA	6 mA	6 mA	6 mA			
		M572T	10 mA	10 mA	13 mA	13 mA			
		M43T	10 mA	10 mA	13 mA	13 mA			
		M63T	10 mA	10 mA	13 mA	13 mA			
Output Logic Levels	Logic High " 1 " (min.)		1.62 V	2.25 V	2.7 V	2.97 V			
	Logic Low " 0 " (max.)		0.25 V	0.25 V	0.3 V	0.33 V			
Standard Frequency (Partial list) [MHz]			10.000	12.800	13.000	14.7456	16.000	16.384	
			19.200	19.440	19.680	20.000	25.000	27.000	
Initial Calibration Tolerance	Models with mechanical trimmer : ± 1.0 ppm. +25°C \pm 2°C. Models without mechanical trimmer : ± 2.0 ppm at +25°C \pm 2°C.								
Frequency Stability (ppm)			± 0.5 ppm	± 1.0 ppm	± 1.5 ppm	± 2.0 ppm	± 2.5 ppm	± 3.0 ppm	O : available Δ : contact us X : not available
Frequency Stability vs Temperature (examples)	0°C to 50°C		O	O	O	O	O	O	
	-10°C to 60°C		Δ	O	O	O	O	O	
	-20°C to 70°C		X	O	O	O	O	O	
	-30°C to 75°C		X	O	O	O	O	O	
	-30°C to 85°C		X	O	O	O	O	O	
-40°C to 85°C		X	Δ	Δ	Δ	O	O		
Frequency Stability	vs Aging at Ta = +25°C		± 1.0 ppm / year (max.)						
	vs Voltage Change		± 0.3 ppm (max.) , for a $\pm 5\%$ input voltage change .						
	vs Load Change		± 0.3 ppm (max.) , for a $\pm 10\%$ load condition change .						
	vs Reflow (SMD type)		± 1.0 ppm (max.) , 1 reflow and measured 24 hours afterwards .						
Electrical Frequency Tuning (EFC) by external Control Voltage	Control Voltage Center		0.9 V \pm 0.6 V (1.8 V) ; 1.4 V \pm 1.0 V (2.5V) ; 1.5 V \pm 1.0 V (3.0V / 3.3V)						
	Frequency Deviation Range		± 5.0 ppm (min.)						
	Slope Polarity (Transfer Function)		Positive slope. Positive voltage for positive frequency shift.						
Control Voltage			Input Impedance : 1.0M Ω (min.)		Modulation Bandwidth : 20 KHz (min.)		Linearity : $\pm 10\%$ (max.)		
Output Load	15 pF								
Duty Cycle	Standard: 50 % \pm 10 % ; Option: 50 % \pm 5 %								
Storage Temperature	-40°C to +85°C or -55°C to +125°C (package dependent)								
Phase Noise [dBc / Hz (typ.)]	Offset	10 Hz	100 Hz	1 KHz	10 KHz	100 KHz			
	M572T33 - 10.000	-96 dBc / Hz	-122 dBc / Hz	-138 dBc / Hz	-145 dBc / Hz	-150 dBc / Hz			

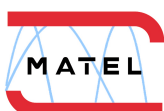

Temperature Compensated Crystal Oscillators [TCXO " M " and VCTCXO " VM "]

CMOS wave output code " T "

Part Number Format and Example

	[1]	[2]	[3]	-	[4]	-	[5]	/	[6]
	Holder Type	Output Wave	Supply Voltage		Center Frequency		Frequency Stability		Operating Temp. Range
Examples	(1) VM39	T	3	-	10.000	-	1.5	/	-20+70
	(2) M572	T	3	-	20.000	-	2.5	/	-30+85

Ex (1) : VM39T3 - 10.000 - 1.5 / -20+70 [VCTCXO , VM39 type , CMOS output , 3.0V , 10.000MHz , ±1.5ppm from -20°C to 70°C]

Ex (2) : M572T3 - 20.000 - 2.5 / -30+85 [TCXO , M572 type , CMOS output , 3.0V , 20.000MHz , ±2.5ppm from -30°C to 85°C]

[1]	Holder Type " M " stands for TCXO , " VM " stands for VCTCXO
[2]	" T " stands for Square Wave ex 1 : M43T --- TCXO , M43 package , CMOS output
[3]	Supply voltage , " 18 " stands for +1.8V ; " 28 " stands for +2.8V ; " 3 " stands for +3.0V ; " 33 " stands for +3.3V
[4]	Center Frequency in MHz
[5]	Frequency stability in ± ppm ; ex 1 : ± 2.5ppm --- 2.5 , ex 2 : ± 1.0ppm --- 1.0
[6]	Operating temperature range in °C ex 1 : -10 °C to 60°C ----- -10+60 ; ex 2 : -20 °C to 70°C ----- -20+70 ; ex 3 : -40 °C to 85°C ----- -40+85

CMOS Typical Phase Noise (M572T33-20.000)

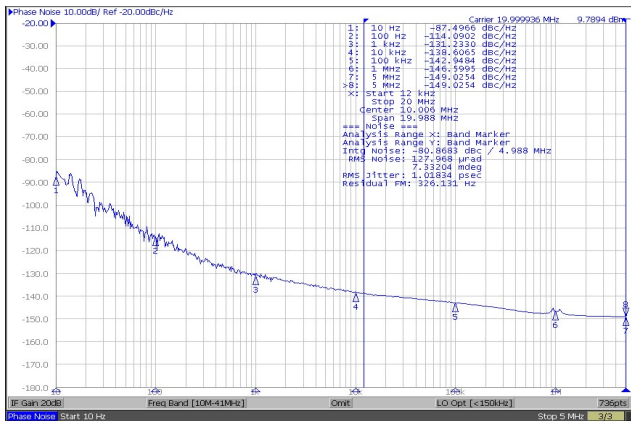

CMOS Output Wave , " T " series

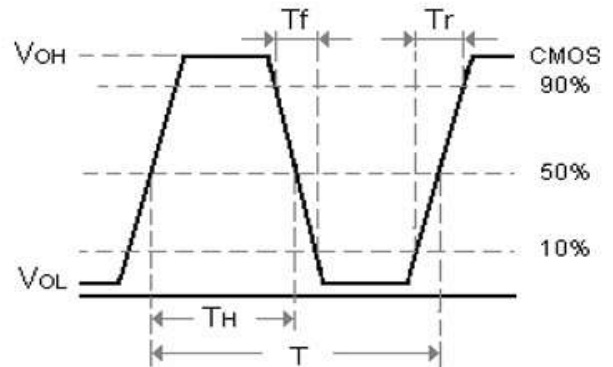

(VC)TCXO with CMOS square wave: Ex. VM14T33

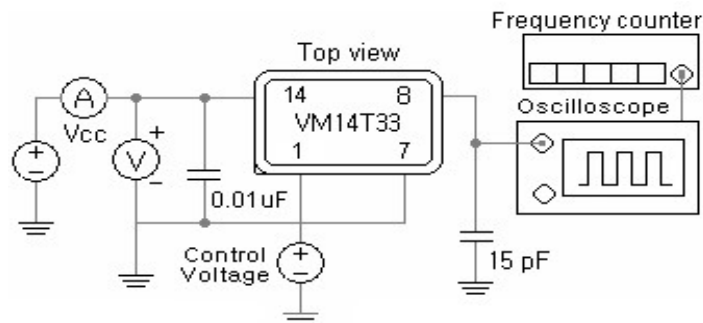

MATEL Centre d'affaires Laroiseau 1 rue Anita Conti 56000 VANNES

+33 (0)2 97 60 98 34 www.matel-piezo.fr

Temperature Compensated Crystal Oscillators [TCXO " M " and VCTCXO " VM "]

CMOS wave output code " T "

Outline Dimensions (Unit : mm) , Suggested pad Layout for SMDs

[(V) M32T_ _]

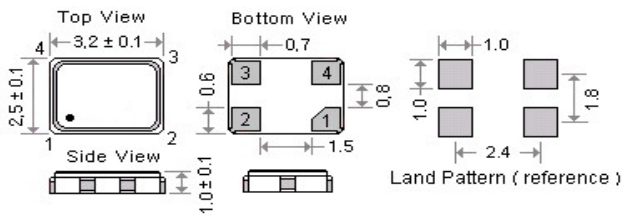

Pad Connections :

Pad 1 : Control voltage for VCTCXO ; Ground for TCXO .

Pad 2 : Ground ; Pin 3 : Output , Pin 4 : Supply Voltage

[(V) M53T_ _]

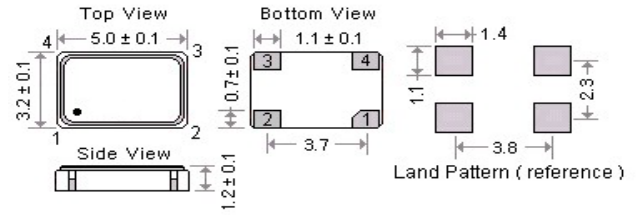

Pad Connections :

Pad 1 : Control voltage for VCTCXO ; Ground for TCXO .

Pad 2 : Ground ; Pad 3 : Output , Pad 4 : Supply Voltage

[(V) M572T_ _]

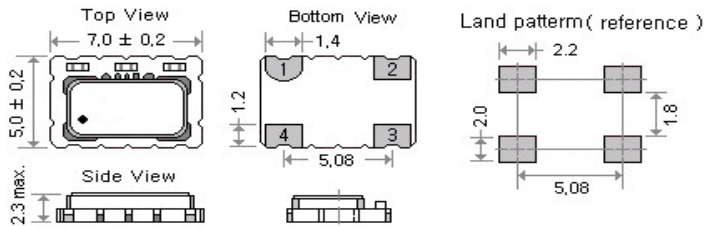

Pad Connections :

Pad 1 : NC --- TCXO ; Vcon --- VCTCXO

Pad 2 : Ground ; Pad 3 : Output , Pad 4 : Supply Voltage

[M_43T_ _] ; [VM_43T_ _]

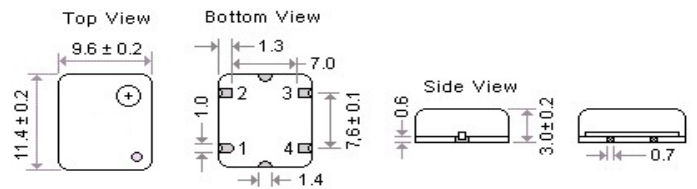

Pad Connections :

Pad 1 : Control voltage for VCTCXO ; Ground for TCXO .

Pad 2 : Ground ; Pad 3 : Output , Pad 4 : Supply Voltage

[M_63T_ _] ; [VM_63T_ _]

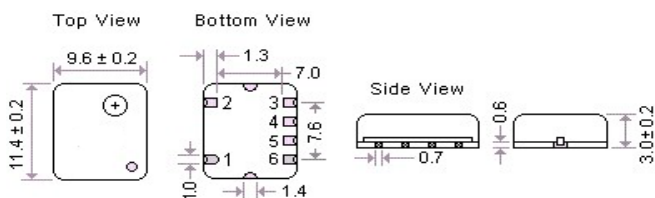

Pad Connections :

Pad 1 , 2 , 4 : Ground , Pad 3 : Output , Pad 6 : Supply Voltage

Pad 5 : Control voltage for VCTCXO. Make no connection if TCXO.

[M_47T_ _] ; [VM_47T_ _]

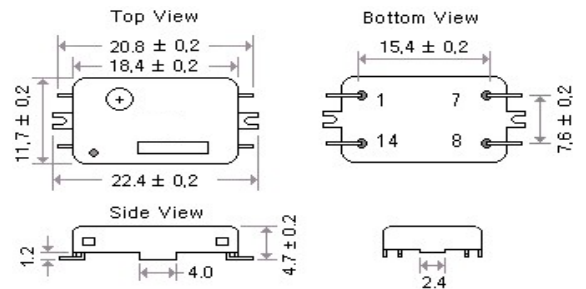

Pad Connections :

Pad 1 : Control voltage for VCTCXO. Make no connection if TCXO.

Pad 7 : Ground ; Pad 8 : Output , Pad 14 : Supply Voltage

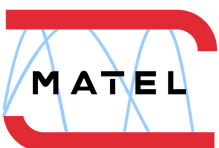

MATEL Centre d'affaires Laroiseau 1 rue Anita Conti 56000 VANNES

+33 (0)2 97 60 98 34 www.matel-piezo.fr

Emboss Taping and Reel Specifications

[VCXO]

[(VC)TCXO]

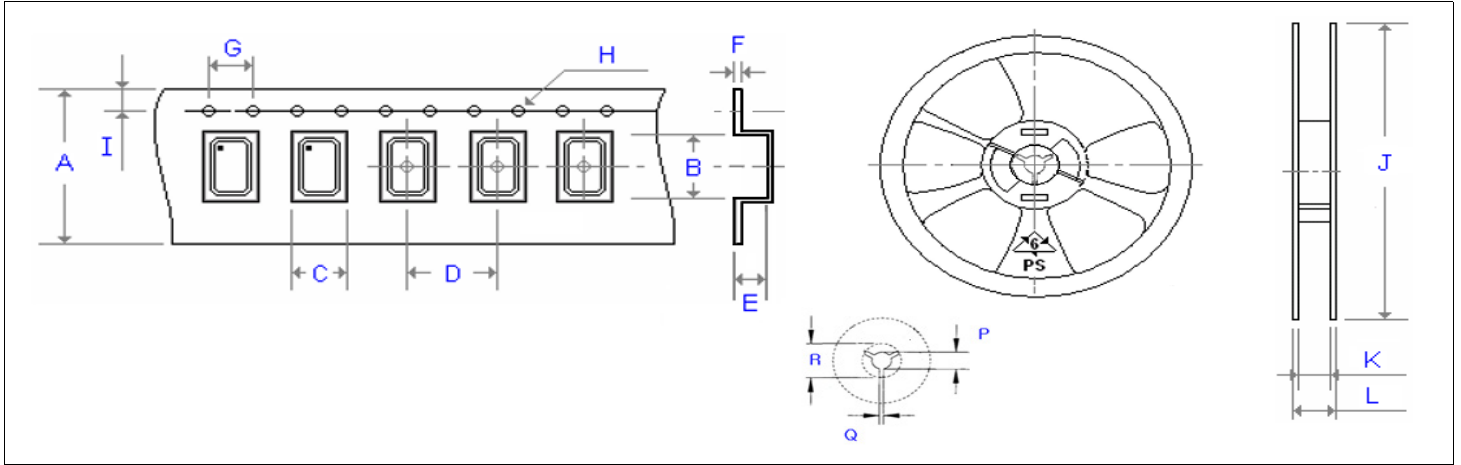

Carrier Type Dimensions (unit : mm) ±0.3mm

	A	B	C	D	E	F	G	H	I	pcs / reel
G_226	8.00	2.80	2.25	4.00	1.10	0.30	4.00	∅ 1.50	1.75	3000
G_326	8.00	3.40	2.70	4.00	1.40	0.25	4.00	∅ 1.50	1.75	3000
G_534	12.00	5.30	3.60	8.00	1.40	0.30	4.00	∅ 1.50	1.75	1000
G_576	16.00	7.30	5.30	8.00	1.90	0.32	4.00	∅ 1.50	1.75	1000
G_43	24.00	11.80	10.00	16.00	5.00	0.30	4.00	∅ 1.50	1.75	500
G_63	24.00	11.80	10.00	16.00	5.00	0.30	4.00	∅ 1.50	1.75	500
G_JF538	12.00	5.30	3.60	8.00	1.40	0.30	4.00	∅ 1.50	1.75	1000
G_JF578	16.00	7.30	5.30	8.00	1.90	0.32	4.00	∅ 1.50	1.75	1000
(V)M21	8.00	2.30	1.90	4.00	0.90	0.25	4.00	∅ 1.50	1.75	3000
ME21	8.00	2.30	1.50	4.00	1.35	0.25	4.00	∅ 1.50	1.75	3000
(V)M22	8.00	2.80	2.25	4.00	1.10	0.30	4.00	∅ 1.50	1.75	3000
(V)M_32	8.00	3.71	2.80	4.00	1.75	0.25	4.00	∅ 1.50	1.75	3000
(V)MQ_326	12.00	3.60	2.90	4.00	1.70	0.30	4.00	∅ 1.50	1.75	3000
(V)M_53	12.00	5.30	3.60	8.00	1.40	0.30	4.00	∅ 1.50	1.75	1000
(V)M_57(2)	16.00	7.40	5.50	8.00	2.80	0.35	4.00	∅ 1.50	1.75	500
(V)M_43 (63)	24.00	11.80	10.00	16.00	5.00	0.30	4.00	∅ 1.50	1.75	500

Reel Dimensions (unit : mm) ±2mm

	J	K	L	P	Q	R	pcs / reel
G_226	180.00	8.40	11.40	13.00	2.50	20.20	3000
G_326	180.00	9.00	12.00	13.00	2.50	20.20	3000
G_534	180.00	13.00	16.00	13.00	2.50	20.20	1000
G_576	180.00	17.20	19.30	13.00	2.50	20.20	1000
G_43	330.00	24.50	29.10	13.00	2.50	20.20	500
G_63	330.00	24.50	29.10	13.00	2.50	20.20	500
G_JF538	180.00	13.00	16.00	13.00	2.50	20.20	1000
G_JF578	180.00	17.20	19.30	13.00	2.50	20.20	1000
(V)M21	180.00	8.40	11.40	13.00	2.50	20.20	3000
ME21	180.00	9.00	12.00	13.00	2.50	20.20	3000
(V)M22	180.00	8.40	11.40	13.00	2.50	20.20	3000
(V)M_32	180.00	9.00	11.40	13.00	2.50	20.20	3000
(V)MQ_326	180.00	13.00	16.00	13.00	2.50	20.20	3000
(V)M_53	180.00	13.00	16.00	13.00	2.50	20.20	1000
(V)M_57(2)	180.00	17.20	19.30	13.00	2.50	20.20	500
(V)M_43 (63)	330.00	24.50	29.10	13.00	2.50	20.20	500



MATEL Centre d'affaires Laroiseau 1 rue Anita Conti 56000 VANNES

+33 (0)2 97 60 98 34 www.matel-piezo.fr