

Crystal Oscillators

CMOS output

Surface Mount type

H21	H22	H32	H53	SWO
2.0 * 1.6 * 0.8	2.5 * 2.0 * 0.9	3.2 * 2.5 * 1.0	5.0 * 3.2 * 1.2	7.0 * 5.0 * 1.4

CMOS

1.0 V	1.8 V	3.3 V
1.2 V	2.5 V	5.0 V

Min.
312 KHz

Max.
160 MHz

Applications

- CPU , Graphics , Multimedia A / V clocks
- MPEG / DVD / HDTV clocks
- Laser engine pixel / set - top clocks
- SONET / SDH / ATM clocks
- Fast Ethernet and Gigabit Ethernet clocks
- NTSC / PAL encoder / decoder clocks
- PLL / synthesizer clocks
- Fibre channel and ADSL clocks

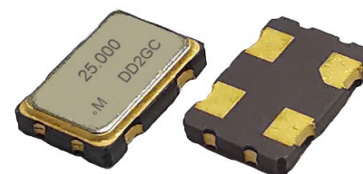

General Specifications [Ta = +25°C , V_{DD}= at specified voltage , Load : 15 pF]

Model	" H21 " ; " H22 " ; " H32 " ; " H53 " and " SWO " series					
Type	" H21 " series	" H22 " series	" H32 " series	" H53 " series	" SWO " series	
Dimensions	2.0 x 1.6 x 0.8 mm	2.5 x 2.0 x 0.9 mm	3.2 x 2.5 x 1.0 mm	5.0 x 3.2 x 1.2 mm	7.0 x 5.0 x 1.4 mm	
Available Frequency Range by Voltage	1.0 V	----	0.75 MHz ~ 50 MHz	0.75 MHz ~ 50 MHz	0.75 MHz ~ 50 MHz	
	1.2 V					
	1.8 V	1 MHz ~ 60 MHz	1.75 MHz ~ 160 MHz	0.312 MHz ~ 160 MHz	0.312 MHz ~ 160 MHz	
	2.5 V					
	3.3 V					
5.0 V	----	1.75 MHz ~ 50 MHz	1.75 MHz ~ 50 MHz	0.375 MHz ~ 100 MHz		
Supply Voltage (V _{DD})	+1.0 V ± 5%	+1.2 V ± 5%	+1.8 V ± 10%	+2.5 V ± 10%	+3.3 V ± 10%	+5.0 V ± 10%
	code is " 10 "	code is " 12 "	code is " 18 "	code is " 25 "	code is " 3 "	code is " 5 "
Output Logic " High " , " 1 "	0.9 V (min.)	1.08 V (min.)	1.62 V (min.)	2.25 V (min.)	2.97 V (min.)	4.5 V (min.)
Output Logic " Low " , " 0 "	0.1 V (max.)	0.12 V (max.)	0.18 V (max.)	0.25 V (max.)	0.33 V (max.)	0.5 V (max.)
Current Consumption	< 25 MHz	4 mA (max.)	4 mA (max.)	5 mA (max.)	5 mA (max.)	5 mA (max.)
	25 ~ 50 MHz	5 mA (max.)	5 mA (max.)	8 mA (max.)	10 mA (max.)	12 mA (max.)
	50 ~ 100 MHz	---	---	10 mA (max.)	15 mA (max.)	30 mA (max.)
	100 ~ 160 MHz	---	---	15 mA (max.)	20 mA (max.)	35 mA (max.)
Rise Time (Tr) / Fall Time (Tf)	6 nsec. (max.)	6 nsec. (max.)	7 nsec. (max.)	7 nsec. (max.)	10 nsec. (max.)	10 nsec. (max.)
	Measured between 10% □ 90% of wave form (CL = 15pF)					
Frequency Stability Codes	Frequency Stability over Operating Temperature Range	± 25 ppm	± 50 ppm	± 100 ppm	If non-standard , please enter the desired stability after the " C " or " I "	
	Commercial (-10°C to +70°C)	A	B	C	For example : " C20 " ±20 ppm over -10°C to +70°C ; " I30 " ± 30 ppm over -40°C to +85°C	
	Industrial (-40°C to +85°C)	D	E	F		
Output Load	15 pF ; (30 pF and 50 pF load are also available for +3.3V and +5.0V V _{DD})					
Duty Cycle	Standard: 50% ± 10%; Option: 50% ± 5%. Please add "-S" at the end of the part number for ± 5% .					
Start -up Time	1.0 ~ 32.0 MHz : 5 msec. (max.) ; 32.1 ~ 160.0 MHz : 10 msec. (max.)					
Storage Temperature	- 55°C to 125°C					
Aging at Ta=+25°C	± 3 ppm per year (max.)					
Output Enable / Disable Function	70% of V _{DD} (min.) to enable output.					
	30% of V _{DD} (max.) to disable output.					
	Disable current : 10 uA max. for OE 0.3V					

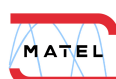

MATEL Centre d'affaires Laroiseau 1 rue Anita Conti 56000 VANNES

+33 (0)2 97 60 98 34 www.matel-piezo.fr

Outline Dimensions (Unit : mm) , Suggested pad Layout for SMDs

[H8 ; H_8]

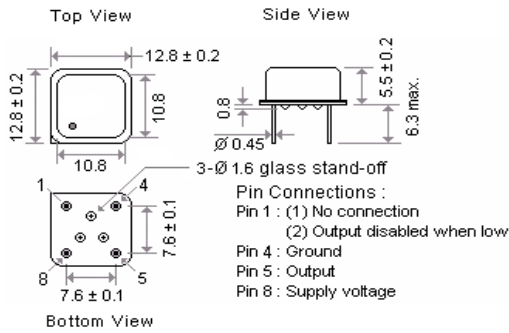

[H14 ; H_14]

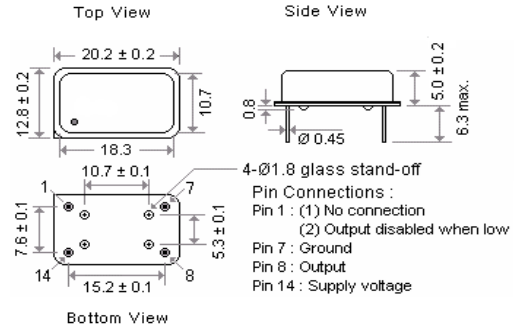

[H21]

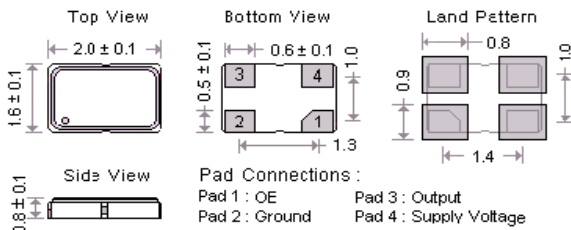

[H22 ; H_22]

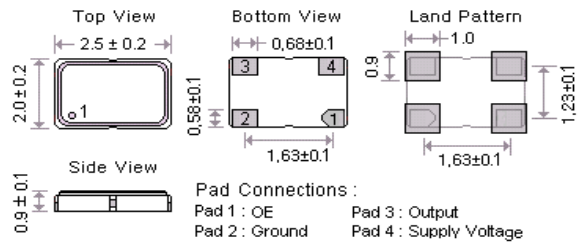

[H32 ; H_32]

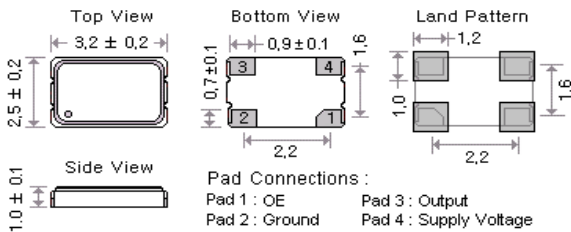

[H53 ; H_53]

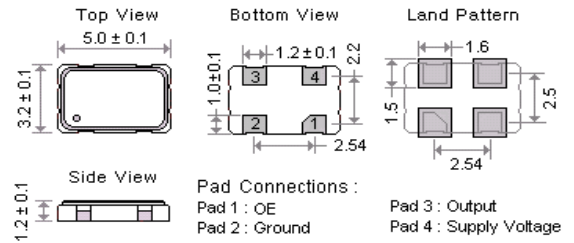

[SWO ; H_57]

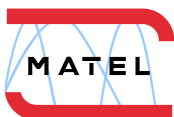
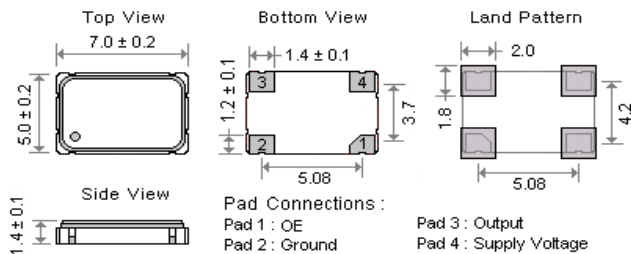

Part Number Format and Examples

	[1]	[2]	-	[3]	[4]	-	[5]
	Supply Voltage	Holder Type		Frequency Stability	OE Function		Center Frequency
Examples	(1)	3	SWO	-	D	T	25.000
	(2)	3	HY32	-	K50	T	24.000
	(3)	18	HA32	-	B	T	32.768K
	(4)	3	HJ22	-	E	T	49.152

- Ex (1) : 3SWO - DT - 25.000 [3.3V , H seires 7050 type , ±25ppm from -40°C to +85°C , OE Function , 25.000MHz]
 Ex (2) : 3HY32 - K50T - 24.000 [3.3V , HY seires 3225 type , ±50ppm from -40°C to +125°C , OE Function , 24.000MHz]
 Ex (3) : 18HA32 - BT - 32.768K [1.8V , HA seires 3225 type , ±50ppm from -10°C to +70°C , OE Function , 32.768KHz]
 Ex (4) : 3HJ22 - ET - 49.152 [3.3V , HJ seires 2520 type , ±50ppm from -40°C to +85°C , OE Function , 49.152 MHz]

[1]	Supply voltage	" 10 " for +1.0V ; " 12 " for +1.2V ; " 18 " for +1.8V ; " 25 " for +2.5V ; " 3 " for +3.3V ; " 5 " for +5.0V
[2]	Holder Type	
[3]	-10°C ~ 70 °C	" A " ± 25ppm ; " B " ± 50ppm ; " C " ± 100ppm ; If non-standard please enter the desired stability after " C " , example " C15 " : represents ±15ppm over -10 to +70°C
	-40°C ~ 85 °C	" D " ± 25ppm ; " E " ± 50ppm ; " F " ± 100ppm ; If non-standard please enter the desired stability after " I " , example " I30 " : represents ± 30ppm over -40 to +85°C
[4]	OE Function	" T " for OE Function , Leave this space blank if no connection on pad 1.
[5]	Frequency in MHz	

Test Circuit & Test Waveform

H ; H_ - series CMOS Test Circuit

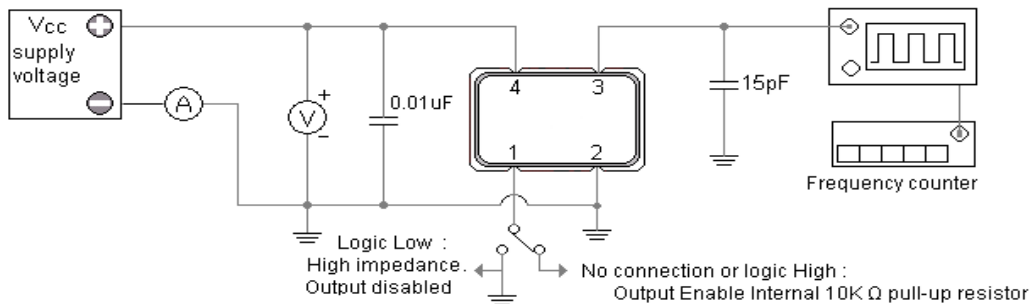

CMOS Output Waveform

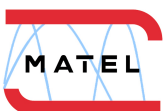
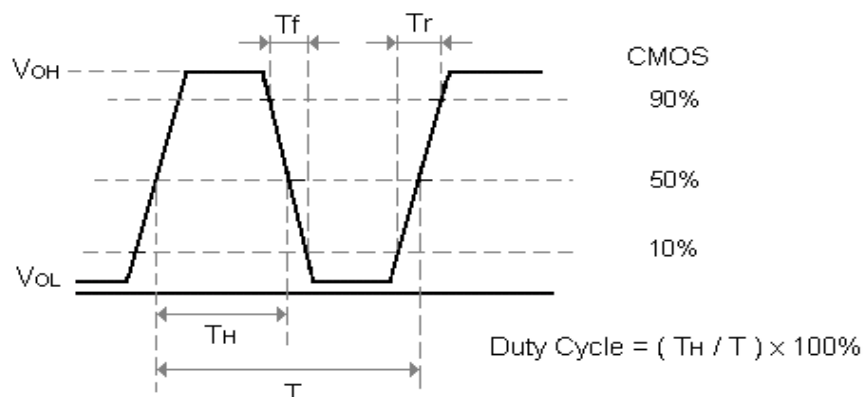

Emboss Taping and Reel Specifications

[Crystal Oscillator Units]

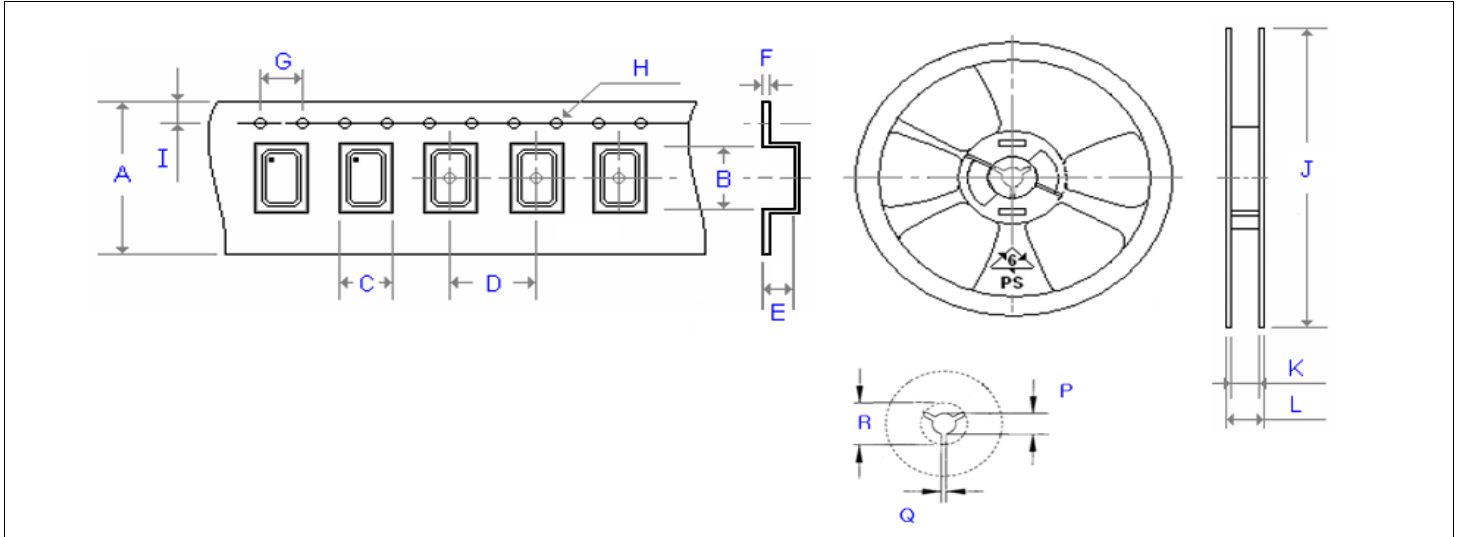

Carrier Type Dimensions (unit : mm) ±0.3mm

	A	B	C	D	E	F	G	H	I	pcs / reel
H21	8.00	2.30	1.90	4.00	0.90	0.25	4.00	Ø 1.50	1.75	3000
H_22	8.00	2.80	2.25	4.00	1.10	0.30	4.00	Ø 1.50	1.75	3000
H_32	8.00	3.40	2.70	4.00	1.40	0.25	4.00	Ø 1.50	1.75	3000
H_53	12.00	5.30	3.60	8.00	1.40	0.30	4.00	Ø 1.50	1.75	1000
H_57	16.00	7.30	5.30	8.00	1.90	0.32	4.00	Ø 1.50	1.75	1000
SWO	16.00	7.20	5.40	8.00	1.80	0.32	4.00	Ø 1.50	1.75	1000
H_226	8.00	2.80	2.25	4.00	1.10	0.30	4.00	Ø 1.50	1.75	3000
H_326	8.00	3.40	2.70	4.00	1.40	0.25	4.00	Ø 1.50	1.75	3000
H_536	12.00	5.30	3.60	8.00	1.40	0.30	4.00	Ø 1.50	1.75	1000
H_576	16.00	7.30	5.30	8.00	1.90	0.32	4.00	Ø 1.50	1.75	1000
H_JF328	8.00	3.40	2.70	4.00	1.40	0.25	4.00	Ø 1.50	1.75	3000
H_JF538	12.00	5.30	3.60	8.00	1.40	0.30	4.00	Ø 1.50	1.75	1000
H_JF578	16.00	7.30	5.30	8.00	1.90	0.32	4.00	Ø 1.50	1.75	1000

Reel Dimensions (unit : mm) ±2mm

	J	K	L	P	Q	R	pcs / reel
H21	180.00	9.00	12.000	13.00	2.50	20.20	3000
H_22	180.00	8.40	11.400	13.00	2.50	20.20	3000
H_32	180.00	9.00	12.000	13.00	2.50	20.20	3000
H_53	180.00	13.00	16.000	13.00	2.50	20.20	1000
H_57	180.00	17.20	19.300	13.00	2.50	20.20	1000
SWO	180.00	17.20	19.300	13.00	2.50	20.20	1000
H_226	180.00	8.40	11.400	13.00	2.50	20.20	3000
H_326	180.00	9.00	12.000	13.00	2.50	20.20	3000
H_536	180.00	13.00	16.000	13.00	2.50	20.20	1000
H_576	180.00	17.20	19.300	13.00	2.50	20.20	1000
H_JF328	180.00	8.00	12.000	13.00	2.50	20.20	3000
H_JF538	180.00	13.00	16.000	13.00	2.50	20.20	1000
H_JF578	180.00	17.20	19.300	13.00	2.50	20.20	1000

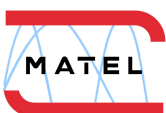

MATEL Centre d'affaires Laroiseau 1 rue Anita Conti 56000 VANNES

+33 (0)2 97 60 98 34 www.matel-piezo.fr